

Application Note

AN2010

D-Series

S7 connection by RS422

V 1.03

Please check www.dimetix.com
for the latest version

Abstract

This Application Notes describe how to connect a D-Series laser sensor to a CP340 interface of a Siemens S7 PLC. The configuration and the wiring is described in this document. In addition to this Application Note an example for the S7 is also available on our website.

This Application Note is provided as is without any warranty for any problems this sample may cause.



Table of content

1	Introduction	3
1.1	Hardware requirements of the PLC.....	3
2	D-Series laser sensor configuration	3
2.1	Wiring.....	4
3	CP340 communication card configuration	5
4	Sample program installation	8
5	Laser sensor control	8
5.1	Sending.....	8
5.2	Receiving.....	9
6	Diagnostic	10
6.1	Status messages of the communication components.....	10

1 Introduction

To connect a D-Series laser sensor with a Siemens S7 PLC different aspects must be considered. This instruction describes the necessary steps to connect the D-Series laser sensor and to run the sample program. This includes the wiring, the configuration and the description of the sample program, which is available under www.dimetix.com. It is essential, that you have some experience in programming of a Siemens S7 PLC.

This sample including its documentation is provided with no warranty for any problems this sample may cause.

1.1 Hardware requirements of the PLC

To successfully run the sample program, you must use a Siemens S7 PLC with an extension card for the RS-232 / RS-422 communication (CP340-RS-422/485; Type: 6ES7 340-1CH00-0AE0).

2 D-Series laser sensor configuration

The CP340 communication card limits the data transfer to 9600 Baud. Therefore the settings of the laser sensor needs to be changed.

Steps	Description
1	Connect the laser sensor over USB or RS-232 to the PC, start the Laser Sensor Utility software and check the connection. Download and install the latest "Laser Sensor Utility" software (www.dimetix.com/UtilitySW).
2	After clicking on the button connection select the baud rate setting 6 under settings (9600 baud, 7 bit, parity even)
3	Accept the messages to change the communication parameter as well
4	Restart the device (power off and wait 5 seconds)

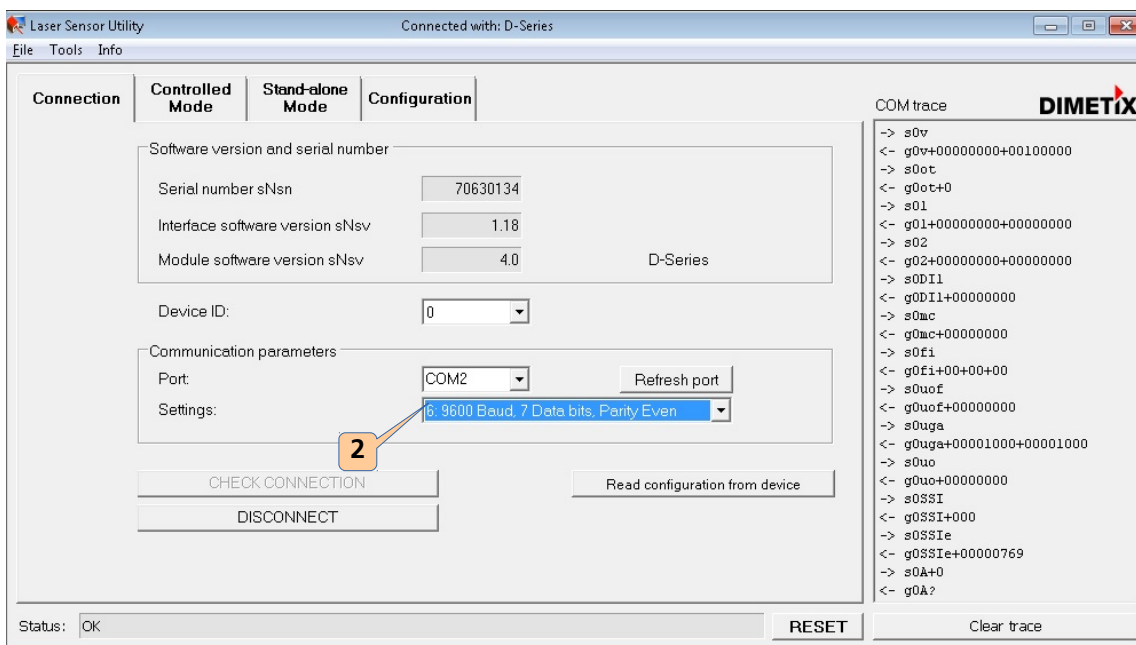

Fig. 1: Select setting number 6 (9600 baud, 7 bit, parity even)



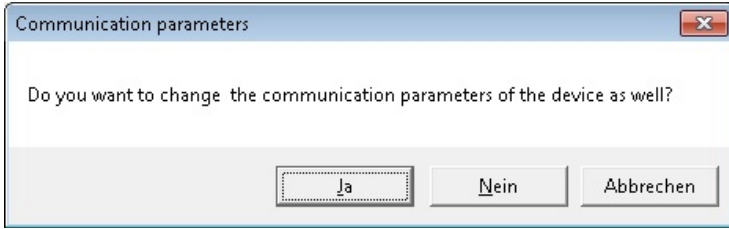

Fig. 2: Select setting number 6 (9600 Baud, 7 bit, parity even)

2.1 Wiring

Connect the laser sensor to the CP340 communication card according to the diagram bellow.

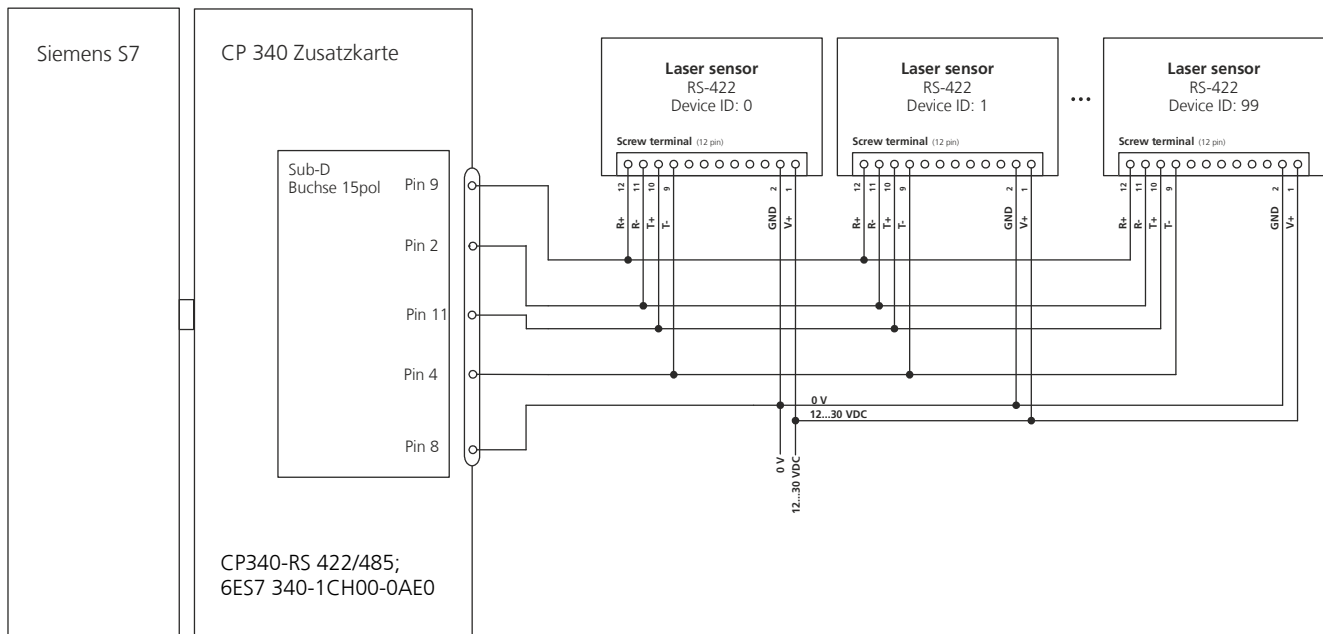

Fig. 3: Select setting number 6 (9600 Baud, 7 bit, parity even)

3 CP340 communication card configuration

Mount the CP340 card in accordance with the instruction included to the card package and run the setup for the card (also included in the CP340 card package). Start the hardware configurator and select the correct part number for the CP340 card. Double click "properties" the assigned address will be displayed. Please write this address down, you will need it later. Next, do the following steps:

Steps	Description
1	Click to "parameters" and select ASCII protocol (Figure 4)
2	Double click on the envelope to define the protocol. Set the configuration exact to the settings as shown in figure 5 to 8. It is essential that all settings are correct, otherwise the communication will not work
3	After all the settings are done save the configuration and download it to the CP340 card

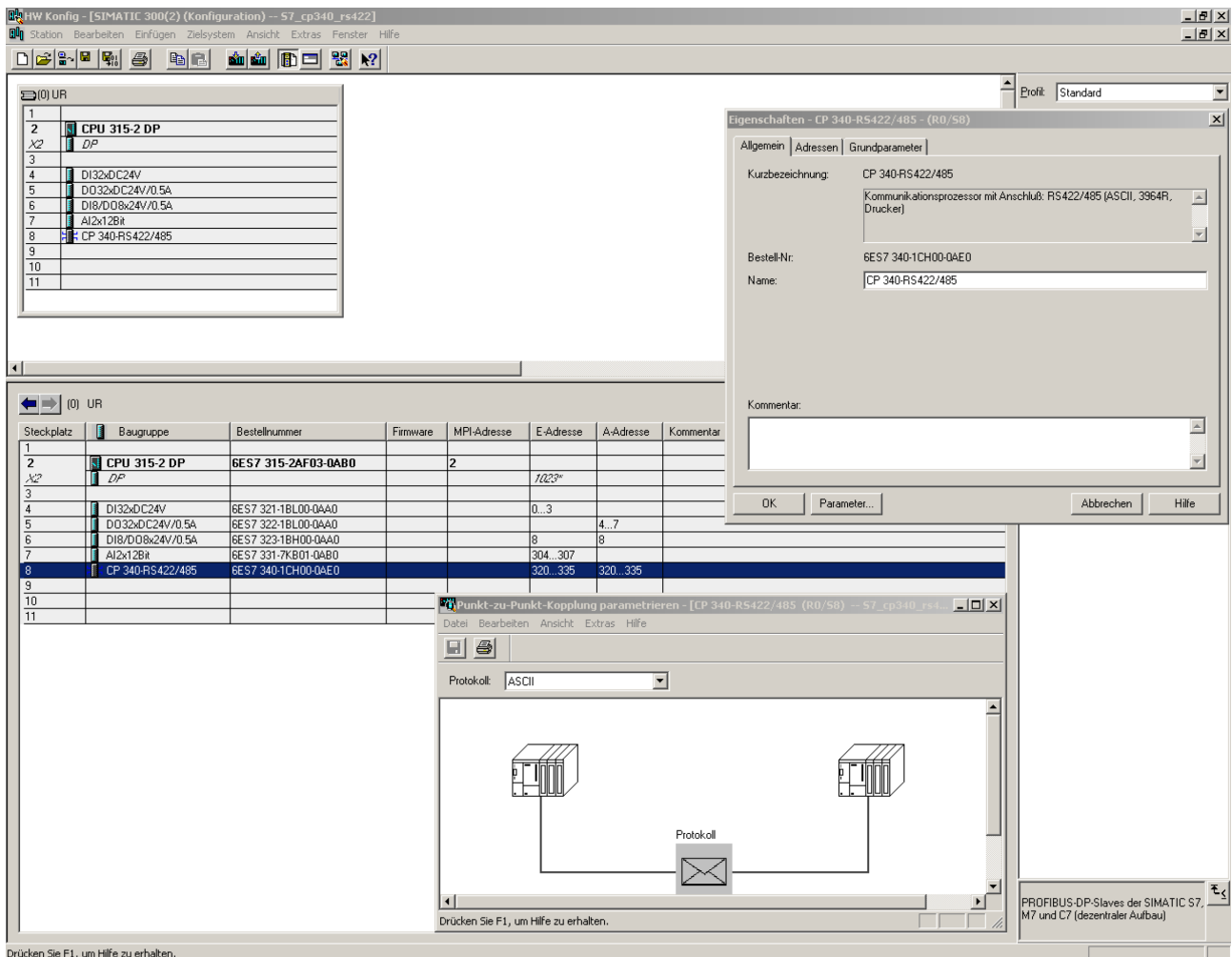

Fig. 4: Protocol configuration

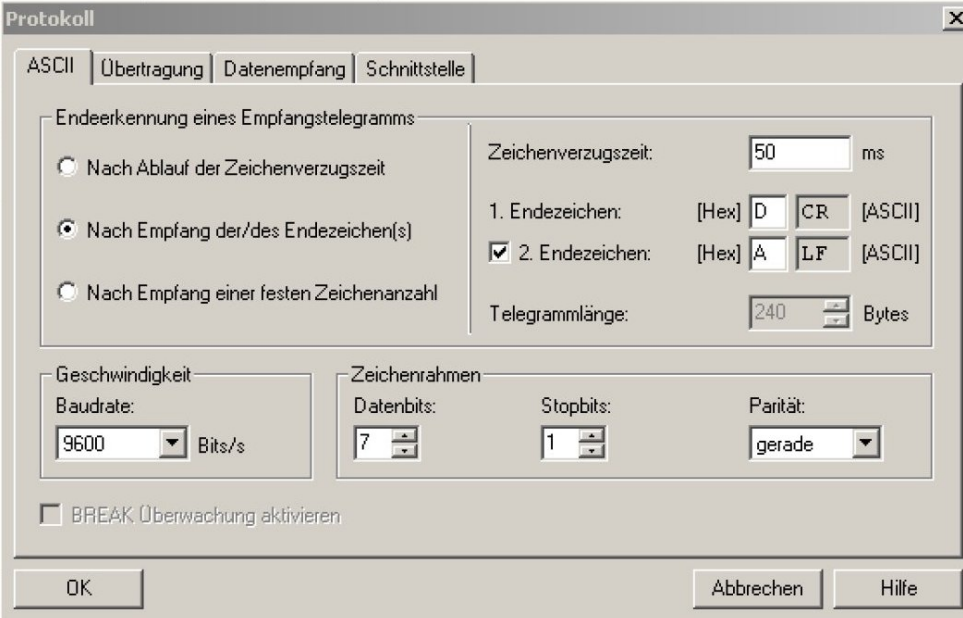

Fig. 5: ASCII configuration

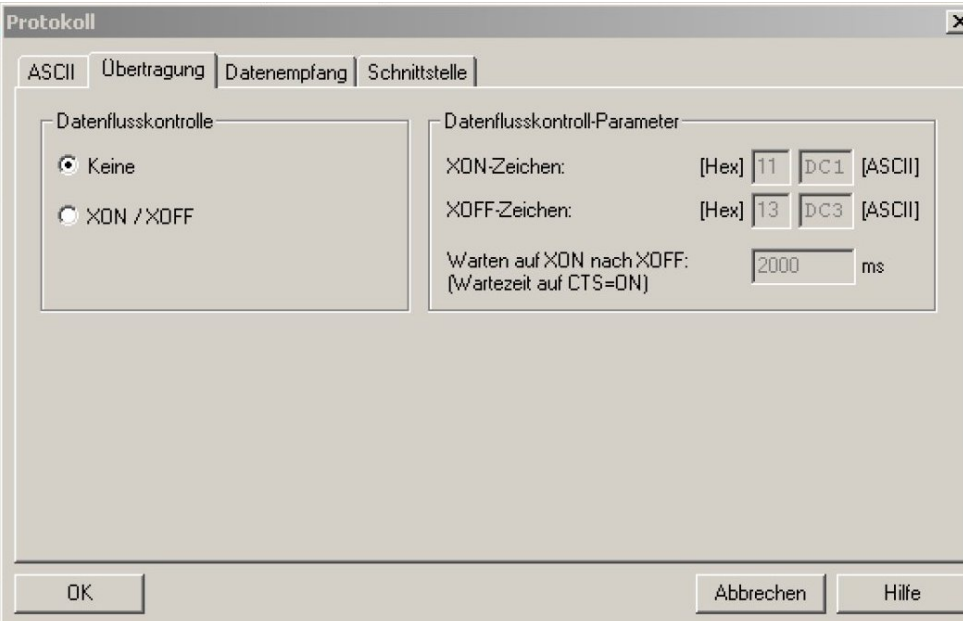

Fig. 6: Transmission



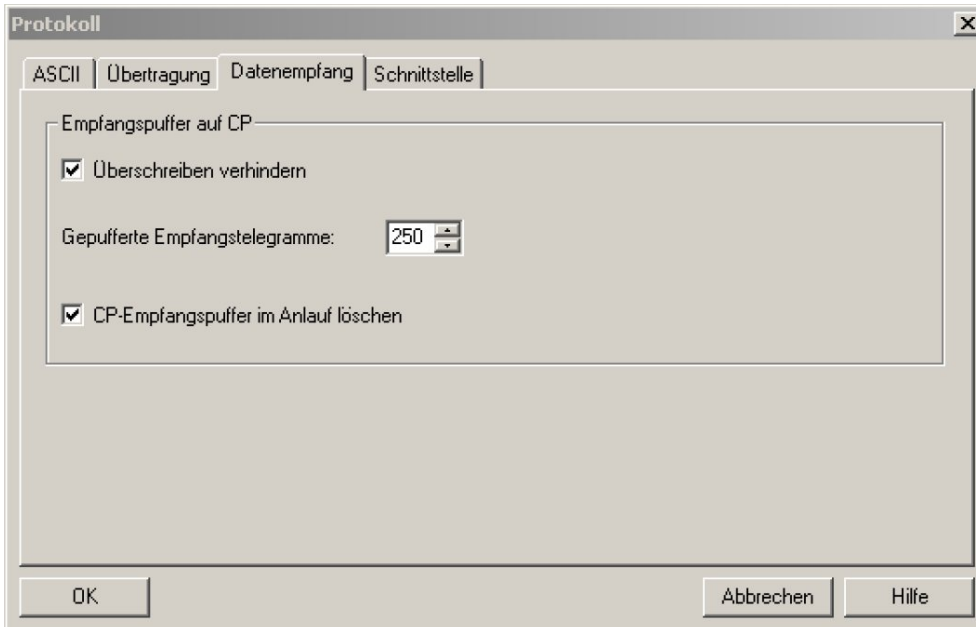

Fig. 7: Receive

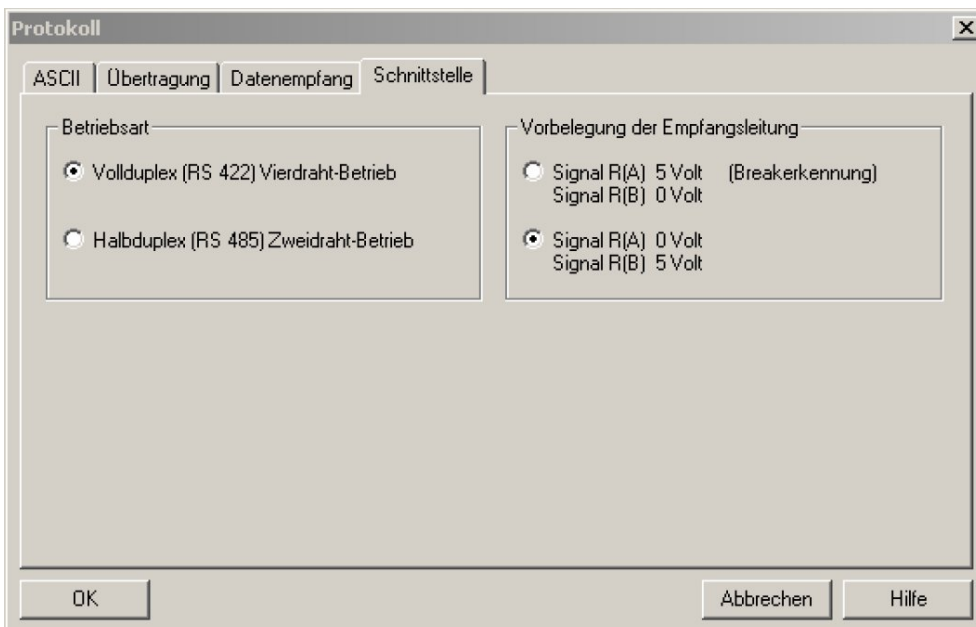

Fig. 8: Interface

4 Sample program installation

Unzip the sample project S7_cp340_dls.zip with the S7 programming environment and copy all blocks (except the system data) into your project. The sample program is available on www.dimetix.com.

The following blocks make up the sample project::

- FC10 Status messages and communication blocks (For debug purposes only; In OB1 deactivated)
- FC11 FC with SEND FC
- 12 FC with RECEIVE
- DB2, DB 3 Instance-DBs for standard Fbs
- DB10 DB for sending
- DB20 DB for receiving
- OB1 Cyclic OB
- OB100 restart (warm start)-OB
- FB2, FB3 standard-FBs for RECEIVE, SEND

Double click on "OB100" and insert the component address of the CP340, which you wrote down earlier. Download your project..

5 Laser sensor control

5.1 Sending

	Description	Corresponding sensor command
MerkerWort 0	Switch communication to ON.	
MerkerWort 1	Switch desired command to ON.	
M1.0	Distance measurement	s0g
M1.1	Laser ON	s0o
M1.2	CLEAR/STOP command	s0c
M1.4	Read out buffer (tracking with buffering)	s0q
M1.5	Start tracking with buffering	s0f

The selected command is executed when a positive edge on Merker 0.6 occurs. During the command transmission the TxD LED on the CP340 card is blinking. An additional positive edge on Merker 0.6 triggers the selected command again. The program allows only one selection at a time. Figure 9 shows the variable control.

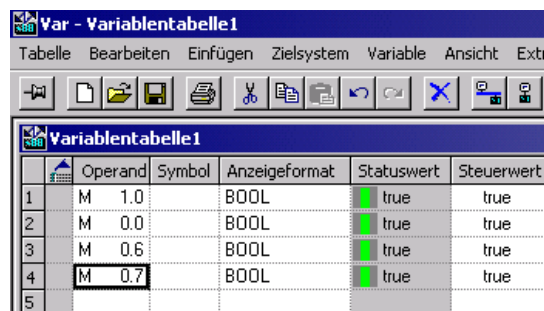

	Operand	Symbol	Anzeigeformat	Statuswert	Steuerwert
1	M 1.0		BOOL	true	true
2	M 0.0		BOOL	true	true
3	M 0.6		BOOL	true	true
4	M 0.7		BOOL	true	true
5					

Fig. 9: Variable control



5.2 Receiving

Enable the receiving by switching the Merker 0.7 of the MW0 ON.

Open "DB20" and switch from the declaration view to the data view. Change "DB20" to online. After triggering a command with a positive edge at Merker 0.6 the DB20 shows the received data (see figure 10). While the CP340 receives data, you will see the RxD LED blinking.

The following figure shows the answer string. It contains the following elements:

- gNg+: Header, N = Sensor ID
- MMMMMMMM: M = measured distance in 1/10 of a millimeter
- \$r \$l: Command / Answer termination (<CR><LF>)

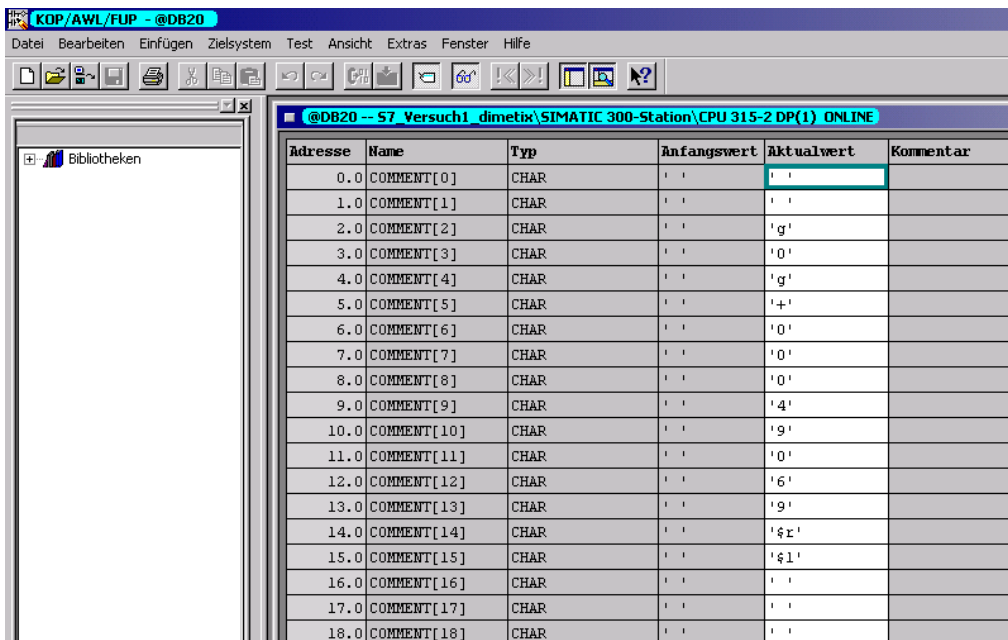

Adresse	Name	Typ	Anfangswert	Aktualwert	Kommentar
0.0	COMMENT[0]	CHAR	' '	' '	
1.0	COMMENT[1]	CHAR	' '	' '	
2.0	COMMENT[2]	CHAR	' '	'g'	
3.0	COMMENT[3]	CHAR	' '	'0'	
4.0	COMMENT[4]	CHAR	' '	'g'	
5.0	COMMENT[5]	CHAR	' '	'+'	
6.0	COMMENT[6]	CHAR	' '	'0'	
7.0	COMMENT[7]	CHAR	' '	'0'	
8.0	COMMENT[8]	CHAR	' '	'0'	
9.0	COMMENT[9]	CHAR	' '	'4'	
10.0	COMMENT[10]	CHAR	' '	'9'	
11.0	COMMENT[11]	CHAR	' '	'0'	
12.0	COMMENT[12]	CHAR	' '	'6'	
13.0	COMMENT[13]	CHAR	' '	'9'	
14.0	COMMENT[14]	CHAR	' '	'\$r'	
15.0	COMMENT[15]	CHAR	' '	'\$l'	
16.0	COMMENT[16]	CHAR	' '	' '	
17.0	COMMENT[17]	CHAR	' '	' '	
18.0	COMMENT[18]	CHAR	' '	' '	

Fig. 10: Data receive



6 Diagnostic

Wrong handling, incorrect wiring or inconsistent configuration result in a sample program, which will not work properly. Please consult the Siemens documentation for instruction how to debug such problems.

6.1 Status messages of the communication components

The FC10 is deactivated in OB1. It has no influence on the function of the communication. The FC10 is made to debug communication problems. Uncomment the entry in OB1 and you can use this block. The following signals will be analyzed:

	Description
M8.0	"Done" of a successful SEND
M8.1	"Error" of an unsuccessful SEND
M8.2	"BR" of a SEND
M8.4	"Done" of a successful RECEIVE
M8.5	"Error" of an unsuccessful RECEIVE
M8.6	"BR" of a RECEIVE

